



QUICK START GUIDE



INDUSTRIAL OUTDOOR HIGH THROUGHPUT 802.11A/N WIRELESS ETHERNET KIT

**This manual serves the following
ComNet Model Numbers:**

NWK7
NWK7E

Thank you for purchasing NetWave® from ComNet. This quick start guide is designed to walk you through installation.

This guide applies to the following models:

NWK7: Industrial Multipoint, FCC Version (Includes NWK7_AP and NWK7_CL)

NWK7E: Industrial Multipoint, ETSI Version (Includes NWK7E_AP and NWK7E_CL)

An easy to read LED array displays unit operational status along with received signal strength ensuring optimal installation and operation. See **Figure 2** on **Page 2** for LED Indicator explanations.

See **Figures 3** through **5** beginning on **Page 3** for mounting instructions.

FIGURE 1 - INDUSTRIAL HIGHTHROUGHPUT WIRELESS ETHERNET LINK



IMPORTANT: Only plug PoE power to Port 1.
Connecting a PoE power source to the PSE Port (#2) will cause a major device malfunction and void the warranty.

FIGURE 2 - STATUS INDICATING LEDS

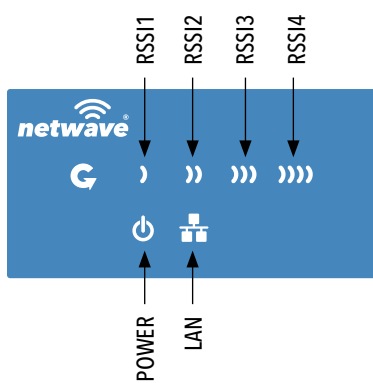

LED	VISUAL CUE	INDICATION
POWER	SOLID GREEN	Power is supplied to the unit
	OFF	No power is supplied to the unit, or the unit is in reset.
LAN	SOLID GREEN	LAN Connected
	OFF	No Connectivity
RSSI1	SOLID RED	Weak Connection
RSSI2	SOLID ORANGE	Moderate Connection
RSSI3	SOLID GREEN	Solid Connection
RSSI4	SOLID GREEN	Excellent Connection (Advisable to check Status Page to confirm RSSI is > -55)

SIGNAL STRENGTH:

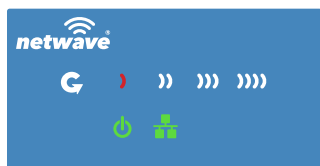

WEAK SIGNAL

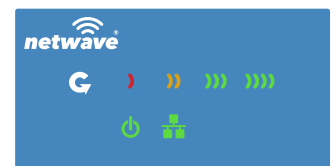
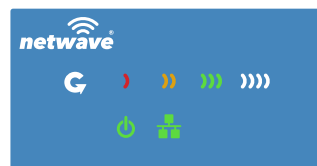
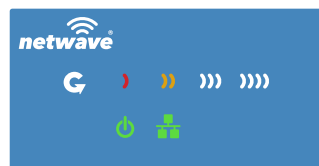

EXCELLENT SIGNAL

FIGURE 3 - INSTALLATION INSTRUCTIONS

Step 1.

Unpack the mounting hardware from the box. Determine if this will be a pole or wall mount application. The included Mounting kit is designed to support poles up to 2 in (5.8 cm) in diameter. If surface or wall mounting, the optional NWBKT hardware will be required.

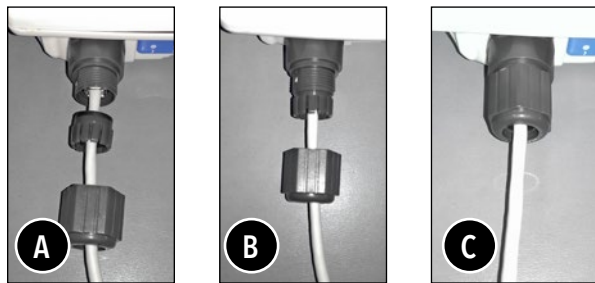
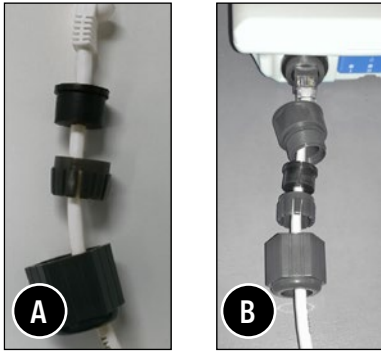

Step 2.

- A. Route the RJ45 connectorized Ethernet cable through the weather tight gland connection as shown at left.
Note: The slit rubber washer allows a pre-terminated Ethernet cable to be used.
Once the cable has been routed through the weather connection as shown above, push the split rubber gasket into place and loosely screw the cap that goes over the rubber washer.

- B. Snap the RJ-45 connector in place as shown

Step 3.

Slide the weather proof assembly over the cable so it can be screwed into the enclosure gland. Make sure the rubber sealing ring is in place as shown in step 3A.

Tighten the weather proof assembly into the enclosure and also tighten the cap that squeezes the rubber washer over the Ethernet cable as shown.

Step 4.

- A. Connect one end of an RJ-45 Ethernet cable to the OUT port of the CNGE11PS or other 35W PoE Injector (sold separately) and the other end to LAN of the access point.

Maximum length of the RJ-45 CAT5 cable is 100 meters.*

- B. Connect the RJ-45 Ethernet cable attached to the PoE Injector to a network device, such as to a switch or to the PC you will use to configure the access point.

- C. Connect the power adaptor to the main electrical supply and the power plug into the socket of the PoE Injector .

PoE power input: Passive PoE (range 36 to 48 VDC). The NWK7[E] can also be powered by a suitable IEEE 802.3af/at PSE device such as a PoE switch or injector.

- D. A Drip Loop is recommended as additional precaution against moisture entering the Access Point housing.

* Up to 200mW radio. For higher power radio upgrade to higher rating power adapter.

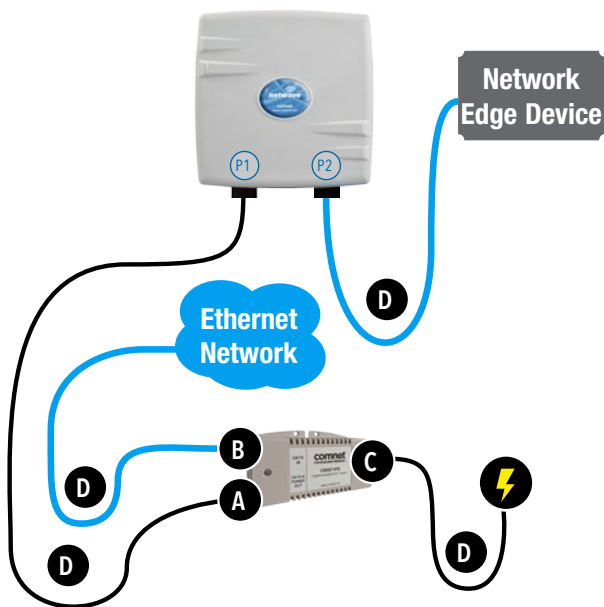
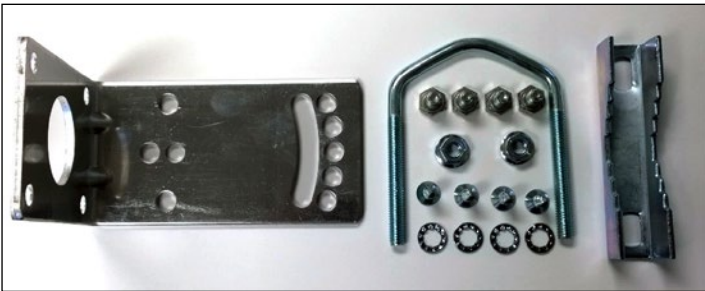

FIGURE 4 - POLE MOUNT INSTRUCTIONS

Included Hardware



Vertical Mount in -45° Position



Vertical Mount in +45° Position



INSTALLATION REQUIREMENTS

Shielded outdoor CAT 5 or better should be used for all out of plant Ethernet connection and should be properly grounded through the PoE AC ground. Industrial grade shielded Ethernet cable is recommended to help prevent ESD damage commonly experienced with outdoor installations. Visit www.comnet.net/comnet-products/cables

CONFIGURING NETWAVE

1. Connect an Ethernet cable from the port labelled as IN on the power Injection Module to either a laptop or a PC LAN port.
2. Connect the second Ethernet cable from the OUT port on the Power Injection Module to the NetWave LAN port.
3. Apply 48 VDC to the Power Injection Module with the provided power supply. You should notice the green LED illuminate in the Power Injection Module and the power LED on the NetWave unit.
4. Set the IP address of the laptop being used to configure NetWave to static and the subnet to 192.168.10.x/24 subnet.
5. Point the Browser to 192.168.10.100 for the Access Point or 192.168.10.101 for the Client. These are the default addresses.
6. A login prompt will pop up. Enter:
ID: **admin**
Password: **admin**
7. Select the NETWORK » Interfaces tab, click on Edit in the LAN settings section to change the IP address of the device. and set the desired network settings.
 - Hit Save & Apply

NOTE: This will be the network address for the NetWave web server. It is not necessary to set to the same subnet as the operating network but it is recommended.
8. Select the NETWORK -> WIFI tab and set:
 - Wireless mode - Set to AP or Client
 - Country code - Only required if setting up the NWK7E and NWK7E/M (ETSI) models

NOTE: It is the user's responsibility to ensure that the correct country is chosen. ComNet accepts no liability for incorrectly set up equipment.

 - Output RF power - if RSSI is greater than -40, it is recommended to reduce RF TX power at the connected remote node.
 - Set SSID - if changing from the default setting
 - Channel Spectrum Width - May want to reduce to 20M from the default 20/40M if the 5GHz spectrum is crowded or connections across the link are unstable.
 - Wireless Security - if changing from default settings
 - Hit Save & Apply

DEFAULT CONFIGURATIONS

IP Address of Web Server	192.168.10.100 (NWKX_AP) 192.168.10.101 for all others
LAN Mode for Web Server	Static Addressing
Web Server User ID	admin
Web Server Password	admin
SSID	NetWave-1
WPA Pre-shared Key	12345678
Channel-Frequency (AP)	Auto
Channel Spectrum Width	20/40M
Long Range Parameters	Enabled and defaulted to 1000m

NOTE: A Reset to defaults (performed on the ADMIN page or via the RESET button) will erase all user configurations.

CONFIGURING MAC LOCK FOR POINT TO POINT LINKS

MAC-Filter replaces MAC-Lock on the first generation Netwave hardware.

MAC-Filter is only available on devices operating as an AP. By default, it is disabled.

You can locate MAC-Filter tab by going to Networking -> WIFI -> Enable.



To enable and lock to a client radio, Click on the drop down menu and select "Allow Listed Only".

A new dialog box will appear. Click on the new dialog box and click on customer, enter the MAC address of the client radio you would like to MAC lock to and hit "Save & Apply".



UNDERSTANDING RSSI AND SIGNAL STRENGTH

The Received Signal Strength Indicator (RSSI) is intended to be used as an indicator of the quality of connection that exists between an Access Point and Client radio.

The RSSI value is determined by the Signal Strength.

Signal Strength is based on a number of factors, including the output power of the radios, antenna gain and the attenuation of the signal as it travels from the transmitter to the receiver.

Signal strength is expressed in dBm. dBm is a power ratio in decibels (dB) referenced to 1mW. Since most received signal levels are under 1mW, negative values are typically displayed. The more negative the number, the weaker the received signal.

The following can be used as a guideline to determine signal quality

RSSI	Signal Quality
Less than -75 to -95 dBm	No Signal or intermittent operation
-75 dBm and greater	Moderate Connection
-65 dBm and greater	Solid Connection
-55 to Zero dBm	Excellent Connection

RESET TO FACTORY DEFAULT

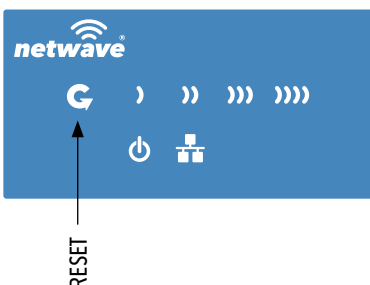

Press and hold the reset button for 4-30 Seconds to reset the radio back to factory defaults.

Note: A simple press of the reset button will restart the radio. Holding the reset button for longer than 30 seconds will not do anything.

Whenever the reset button is pressed, the power LED will go dark.

TYPICAL POINT-TO-POINT CONFIGURATIONS

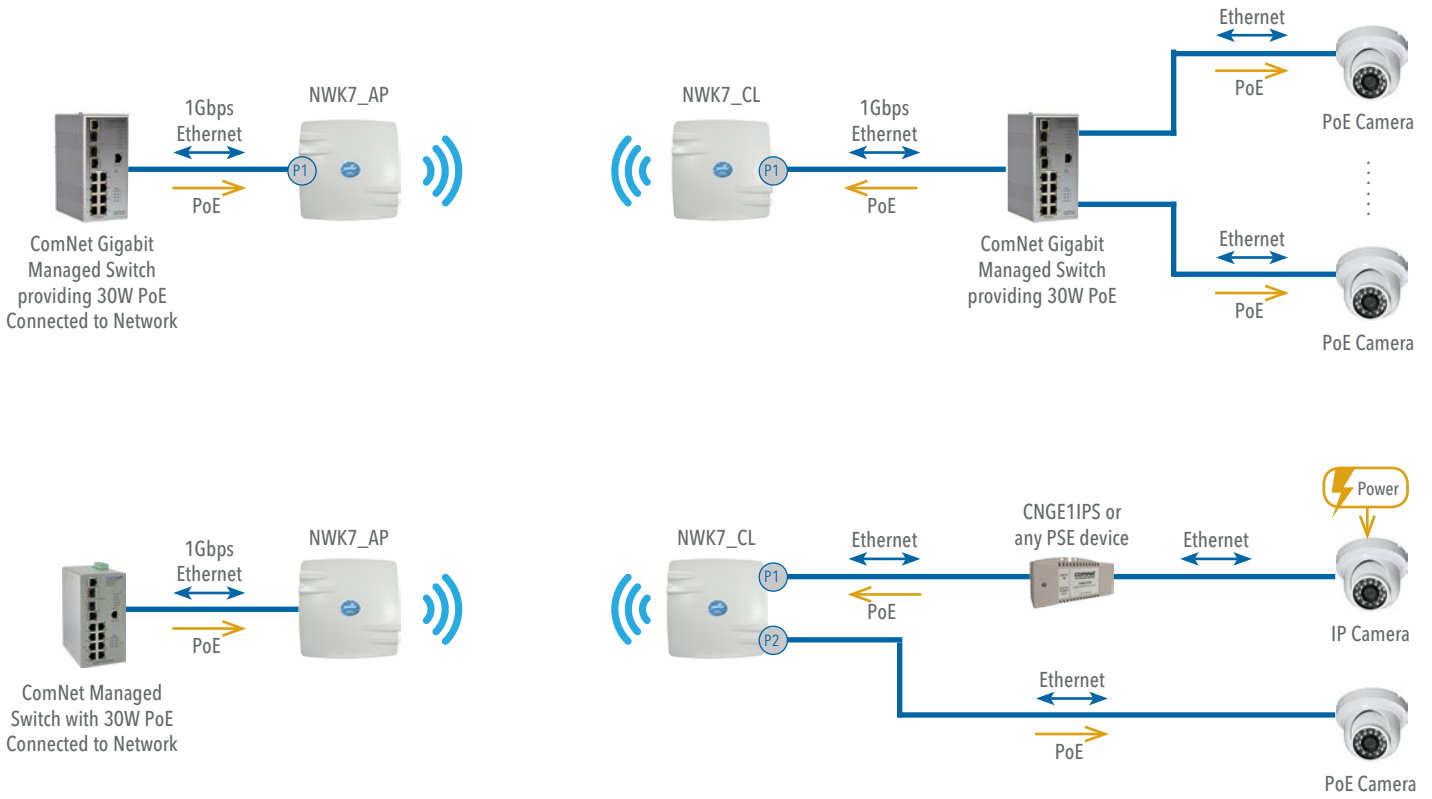

AGENCY COMPLIANCE

FCC

Changes or modifications not expressly approved by the party responsible for compliance could void the user's authority to operate the equipment. This device complies with Part 15 of the FCC Rules. Operation is subject to the following two conditions:

- This device may not cause harmful interference, and
- This device must accept any interference received, including interference that may cause undesired operation.

This equipment has been tested and found to comply with the limits for a Class A digital device, pursuant to part 15 of the FCC Rules. These limits are designed to provide reasonable protection against harmful interference when the equipment is operated in a commercial environment. This equipment generates, uses, and can radiate radio frequency energy and, if not installed and used in accordance with the instruction manual, may cause harmful interference to radio communications. Operations of this equipment in a residential area is likely to cause harmful interference in which case the user will be required to correct the interference at his own expense.

Industry Canada

This Class A digital apparatus complies with Canadian ICES-003. To reduce potential radio interference to other users, the antenna type and its gain should be so chosen that the equivalent isotropically radiated power (EIRP) is not more than that permitted for successful communication. This device complies with Industry Canada license-exempt RSS standard(s).

Operation is subject to the following two conditions:

- This device may not cause interference, and
- This device must accept any interference, including interference that may cause undesired operation of the device.

Cet appareil numérique de la classe A est conforme à la norme NMB-003 Canada. Pour réduire le risque d'interférence aux autres utilisateurs, le type d'antenne et son gain doivent être choisies de façon que la puissance isotrope rayonnée équivalente (PIRE) ne dépasse pas ce qui est nécessaire

pour une communication réussie. Cet appareil est conforme à la norme RSS Industrie Canada exempts de licence norme(s). Son fonctionnement est soumis aux deux conditions suivantes:

17 Compliance

- Cet appareil ne peut pas provoquer d'interférences et
- Cet appareil doit accepter toute interférence, y compris les interférences qui peuvent causer un mauvais fonctionnement du dispositif.

RF Exposure Warning

The antennas used for this transmitter must be installed to provide a separation distance of at least 2.52m from all persons and must not be located or operating in conjunction with any other antenna or transmitter.

Les antennes utilisées pour ce transmetteur doivent être installées en considérant une distance de séparation de toute personnes d'au moins 2.52m et ne doivent pas être localisées ou utilisées en conflit avec tout autre antenne ou transmetteur.

CE Marking

CE marking on this product represents the product is in compliance with all directives that are applicable to it.

This equipment may be operated in the following countries:

Austria, Belgium, Denmark, Estonia, Finland, France, Germany, Greece, Hungary, Ireland, Italy, Latvia, Lithuania, Malta, Netherlands, Norway, Portugal, Romania, Czech Republic, Croatia, Slovakia, Slovenia, Sweden, UK

Installer Compliance Responsibility

Devices must be professionally installed and it is the professional installer's responsibility to make sure the device is operated within local country regulatory requirements.

RoHS/WEEE Compliance Statement

European Directive 2002/96/EC requires that the equipment bearing this symbol on the product and/or its packaging must not be disposed of with unsorted municipal waste. The symbol indicates that this product should be disposed of separately from regular household waste streams. It is your responsibility to dispose of this and other electric and electronic equipment via designated collection facilities appointed by the government or local authorities. Correct disposal and recycling will help prevent potential negative consequences to the environment and human health. For more detailed information about the disposal of your old equipment, please contact your local authorities, waste disposal service, or the shop where you purchased the product.

Need Additional Assistance?

Visit our website <http://www.comnet.net> or contact Comnet tech support:

Tel: (203) 796-5300

Toll free: (888) 678-9427

Email: techsupport@comnet.net

Additional Technical support contact details can be found at:

<http://www.comnet.net/services/technical-support.html>

Or Visit our pre-sales design center:

<http://www.comnet.net/services/design-center.html>

Or our customer care:

<http://www.comnet.net/services/customer-care.html>

Additional Downloads

Datasheets, Installation manuals and other product documentation can be found at:

<http://www.comnet.net/comnet-products/ethernet/wireless/>



3 CORPORATE DRIVE | DANBURY, CT 06810 | USA

T: 203.796.5300 | F: 203.796.5303 | TECH SUPPORT: 1.888.678.9427 | INFO@COMNET.NET

8 TURNBERRY PARK ROAD | GILDERSOME | MORLEY | LEEDS, UK LS27 7LE

T: +44 (0)113 307 6400 | F: +44 (0)113 253 7462 | INFO-EUROPE@COMNET.NET