



## INSTALLATION AND OPERATION MANUAL

# FVT/FVR2014

## 2-CHANNEL 10-BIT DIGITALLY ENCODED VIDEO + 4 BI-DIRECTIONAL DATA CHANNELS

The FVT/FVR2014 is a two (2) channel ten (10) bit video transmission system. It combines two individual video signals into one high speed digital stream and transmits this over one optical fiber.

The link also transmits four channels of bi-directional data over the same fiber. Each data channel can be configured for an electrical interface of RS232, RS422 or RS485 (2- or 4-Wire).

There is also a RELAY connector on both the Video Transmitter and Video Receiver modules which indicates that the optical communication link is operating properly. The Relay is CLOSED when the optical communication is good.

The Data Channels are labeled A, B, C and D. Each data channel is configured for the electrical interface by means of the “DATA SELECT” switch on the front panel. **Figure 5** on **Page 4** illustrates the switch settings to set the type of data for each channel.

**Figure 4** on **Page 3** illustrates the data electrical connections from the RJ45 Data connectors and also the connection cable and “breakout box” connections.

**Figure 6** on **Page 4** illustrates the specific data connections for RS232, 2-Wire RS485 and RS422/4-Wire RS485. (This last data connection also applies to Manchester & Bi-Phase data transmission.)

**Figure 7** on **Page 5** illustrates the electrical connections between the “Customer Equipment” and the FVT2014 and FVR2014.

FIGURE 1 – FVT/FVR2014 TRANSMITTER AND RECEIVER

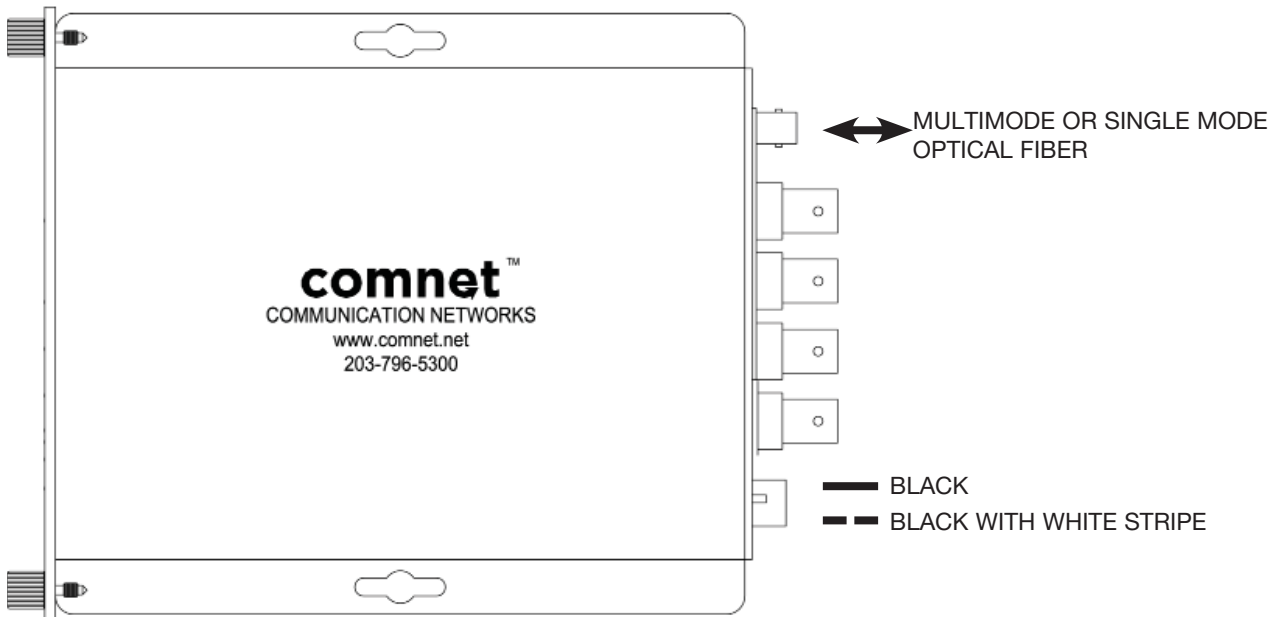

FIGURE 2 – FVT2014 TRANSMITTER

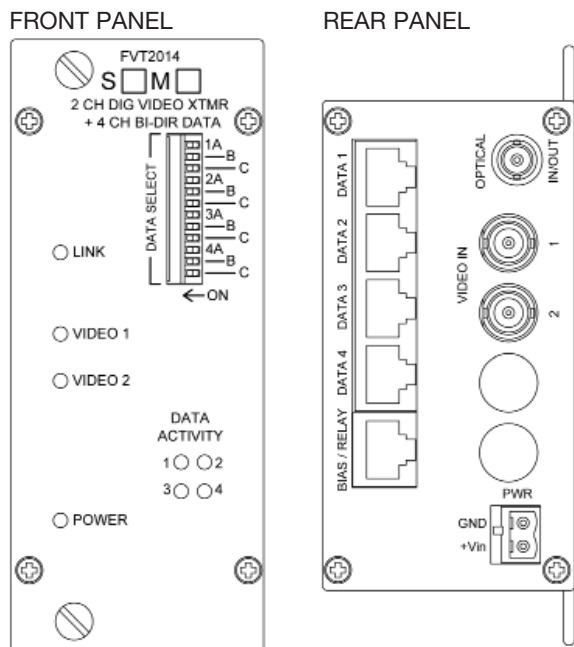
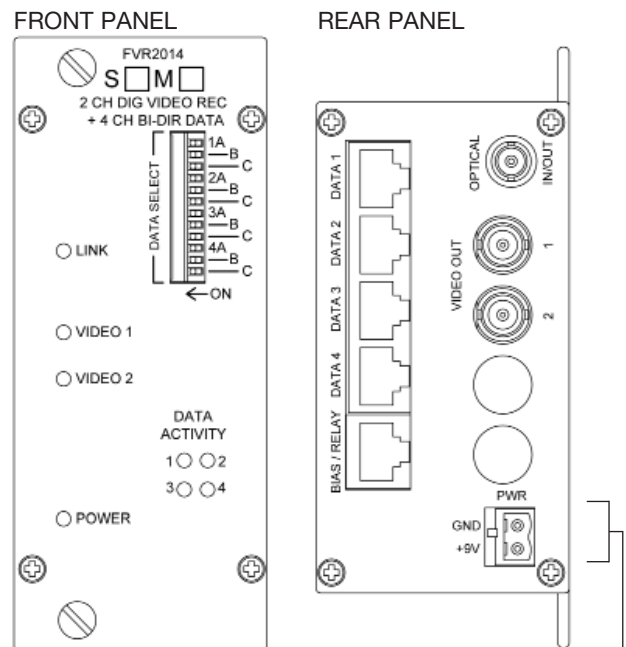

FIGURE 3 – FVR2014 RECEIVER



NOTE: Remove Electrical Connector for Rack Mount Units

**FIGURE 4 – RJ45 BREAK-OUT**

5 pc. Factory Supplied

**CONNECTIONS FOR EACH DATA CHANNEL**

**NOTE:** A 120 OHM TERMINATION RESISTOR IS APPLIED TO THE DIFFERENTIAL INPUTS WHEN "TERMINATION (PIN 5)" IS WIRED DIRECTLY TO "DIN- (PIN 6)" SEE DIAGRAM BELOW

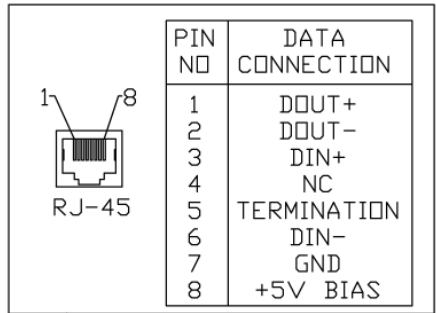

**VIEW INSIDE PORT**

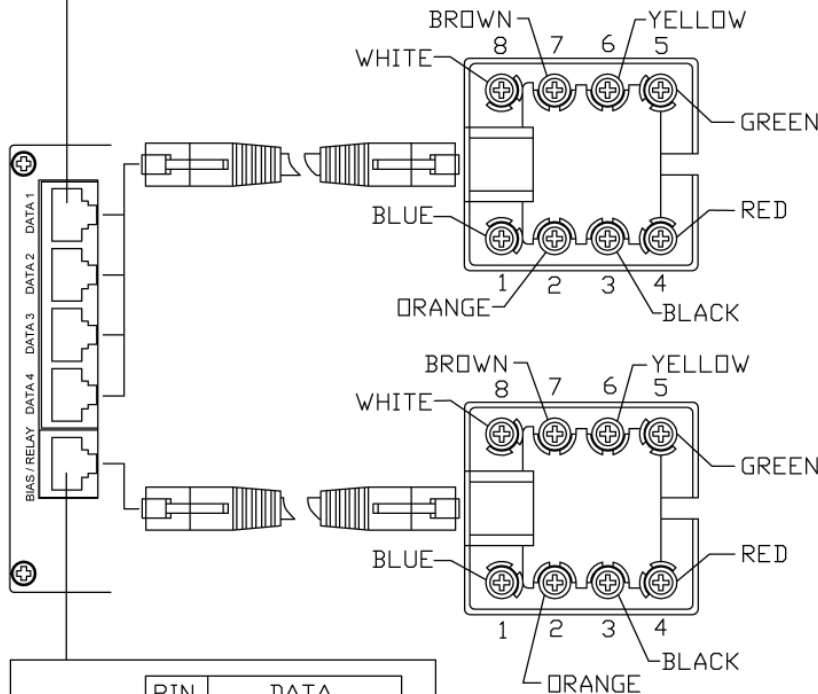
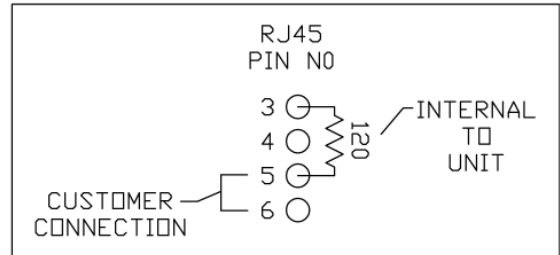

RJ45 PIN NO	WIRE COLOR	DATA CONNECTION
1	BLUE	DOUT+
2	ORANGE	DOUT-
3	BLACK	DIN+
4	RED	NC
5	GREEN	TERMINATION
6	YELLOW	DIN-
7	BROWN	GND
8	WHITE	+5V BIAS

RJ45 PIN NO	WIRE COLOR	DATA CONNECTION
1	BLUE	+5V BIAS
2	ORANGE	+5V BIAS
3	BLACK	+5V BIAS
4	RED	GND
5	GREEN	GND
6	YELLOW	GND
7	BROWN	ALARM RELAY
8	WHITE	ALARM RELAY

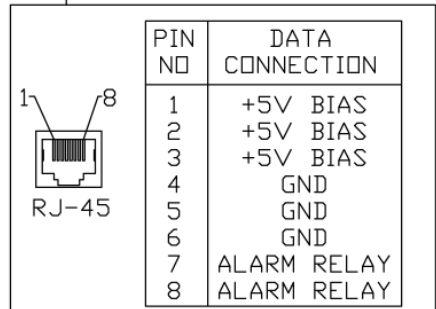

**VIEW INSIDE PORT**

**BIAS AND RELAY CONNECTIONS**

**FIGURE 5 – SWITCH POSITIONS**

The mode for each data channel is configured using a set of three switches on the front panel of the unit.

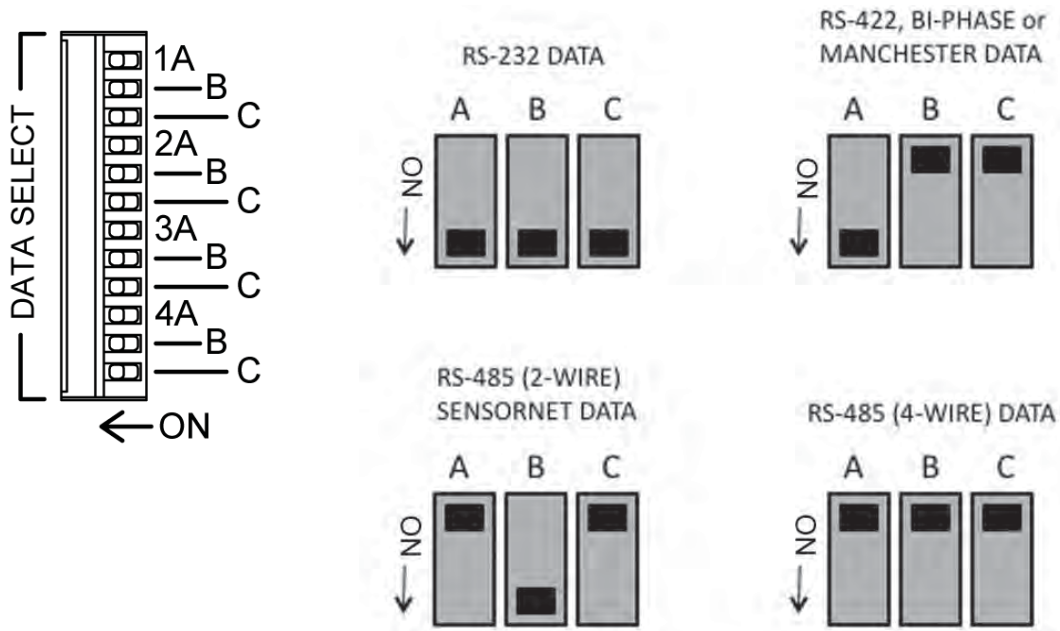

**FIGURE 6 – SWITCH SETTINGS**

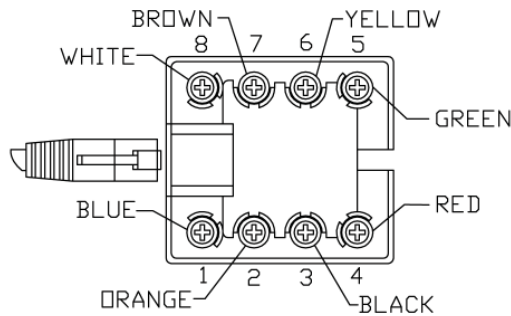

RJ45 PIN NO	WIRE COLOR	DATA CONNECTION
1	BLUE	DOUT+
2	ORANGE	DOUT-
3	BLACK	DIN+
4	RED	NC
5	GREEN	TERMINATION
6	YELLOW	DIN-
7	BROWN	GND
8	WHITE	+5V BIAS

**RS232**

- 1 NC
- 2 Out (-)
- 3 Ground
- 4 NC
- 5 NC
- 6 IN (-)
- 7 NC
- 8 NC

**RS485 (2W) & SENSORNET**

- 1 NC
- 2 NC
- 3 IN (+)
- 4 NC
- 5 NC
- 6 IN (-)
- 7 NC
- 8 NC

**RS422, RS485 (4W), Manchester & Bi-Phase**

- 1 OUT (+)
- 2 OUT (-)
- 3 IN (+)
- 4 NC
- 5 NC
- 6 IN (-)
- 7 NC
- 8 NC

NC = No Connection

**FIGURE 7 – DATA CONNECTIONS**

See Page 4 for Switch Settings

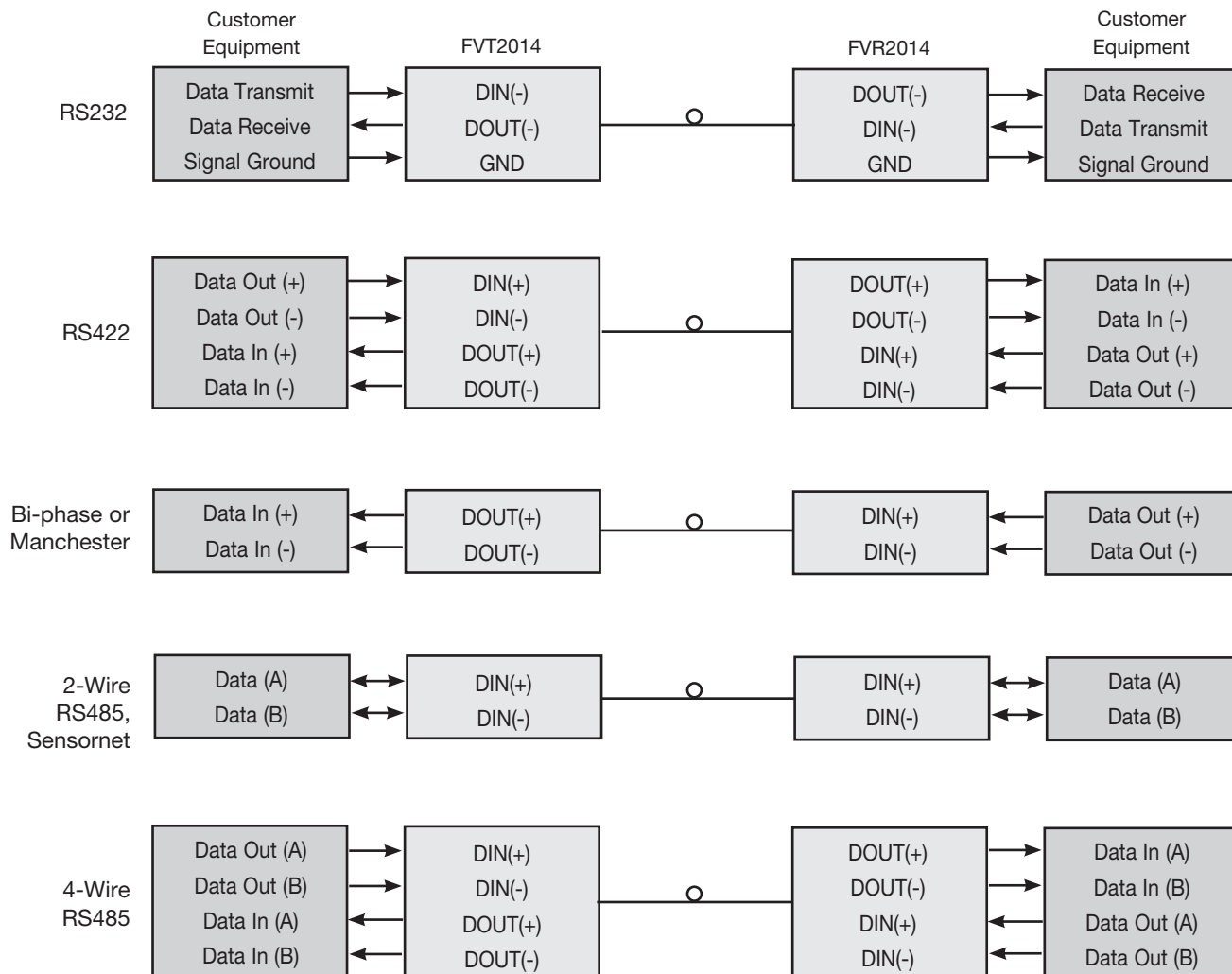

**FIGURE 8 – LED INDICATORS**

	LINK	VIDEO	DATA	POWER
GREEN	Communication link has been established over optical fiber	An active video signal is present on the BNC connector.	An active data signal is present on the input pins of the data connector.	Unit powered up
RED	Communication link has not been established.	No video signal	–	–
OFF	Not powered up correctly	–	No data signal	Unit powered down

# MECHANICAL INSTALLATION INSTRUCTIONS

## INSTALLATION CONSIDERATIONS

This fiber-optic link is supplied as a Standalone/Rack module. Units should be installed in dry locations protected from extremes of temperature and humidity.

## C1-US, C1-EU, C1-AU OR C1-CH CARD CAGE RACKS

**CAUTION:** Although the units are hot-swappable and may be installed without turning power off to the rack, ComNet recommends that the power supply be turned off and that the rack power supply is disconnected from any power source. **Note:** Remove electrical connector before installing in card cage rack.

1. Make sure that the card is oriented right side up, and slide it into the card guides in the rack until the edge connector at the back of the card seats in the corresponding slot in the rack's connector panel. Seating may require thumb pressure on the top and bottom of the card's front panel.

**CAUTION:** Take care not to press on any of the LEDs.

2. Tighten the two thumb screws on the card until the front panel of the card is seated against the front of the rack.

**WARNING:** Unit is to be used with a Listed Class 2 or LPS power supply rated 9-12 VDC @ 1A.

### IMPORTANT SAFEGUARDS:

**A) Elevated Operating Ambient** - If installed in a closed or multi-unit rack assembly, the operating ambient temperature of the rack environment may be greater than room ambient. Therefore, consideration should be given to installing the equipment in an environment compatible with the maximum ambient temperature (T<sub>ma</sub>) specified by the manufacturer.

**B) Reduced Air Flow** - Installation of the equipment in a rack should be such that the amount of air flow required for safe operation of the equipment is not compromised.

## FIGURE A

Dimensions are for a standard ComNet™ two slot module

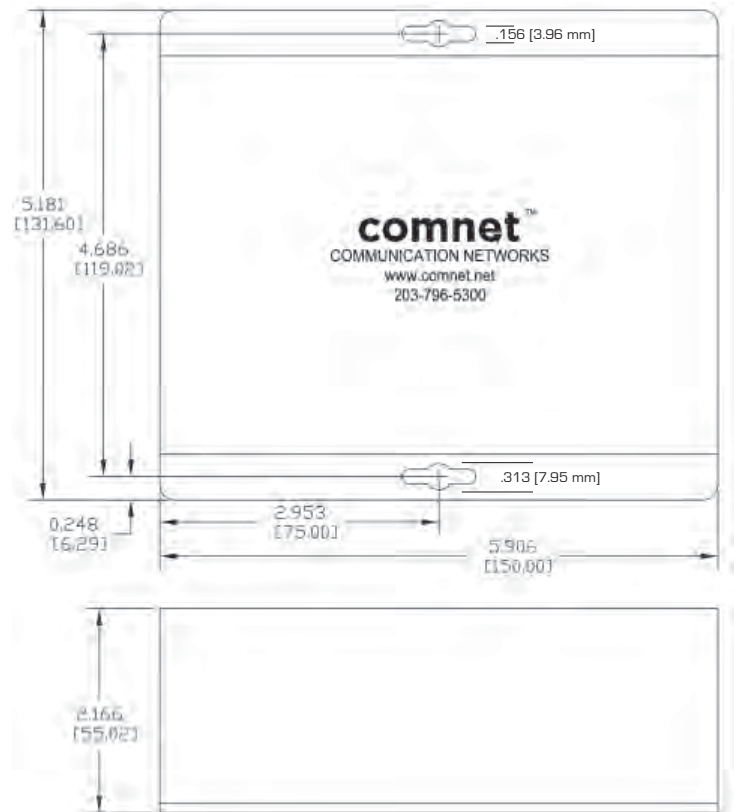

MADE IN THE  
**USA**

**comnet**  
Communication Networks

3 CORPORATE DRIVE | DANBURY, CT 06810 | USA  
T: 203.796.5300 | F: 203.796.5303 | TECH SUPPORT: 1.888.678.9427 | INFO@COMNET.NET

8 TURNBERRY PARK ROAD | GILDERSOME | MORLEY | LEEDS, UK LS27 7LE  
T: +44 (0)113 307 6400 | F: +44 (0)113 253 7462 | INFO-EUROPE@COMNET.NET

INS\_FVT/FVR2014\_REVA  
05/10/10  
PAGE 6