



INSTALLATION AND OPERATION MANUAL

FDXT1/E1(M,S)1(A,B) T1/E1 POINT-TO-POINT TRANSCEIVER

FDXT1/E1(M,S)1(A,B)/R3 T1 POINT-TO-POINT TRANSCEIVER

The ComNet™ FDXT1/E1 data transceivers are T1/E1 links that support AMI and B8ZS data signals over one single mode or multimode optical fiber. The transceivers synchronize and regenerate data to eliminate jitter accumulated through the link. Models within this series are available for use with multimode or single mode optical fiber. Plug-and-play design ensures ease of installation requiring no electrical or optical adjustments.

Each transceiver incorporates a bi-color (Red/Green) indicating LED for monitoring proper system operation. See **Figure 6 on Page 5** for an explanation of LED indications.

The FDXT1/E1 standard size units may be either wall or rack-mounted in a ComNet card cage, or may be installed in an IFS R3 rack with the selection of the corresponding model. See **Figure A on Page 5** for mounting instructions.

See **Figures 1 - 6** for complete installation details.

Please note that the FDXT1/E1/R3 IFS-compatible units support T1 links only.

FIGURE 1 - FDXT1/E1 ComFit Units

SIDE VIEW

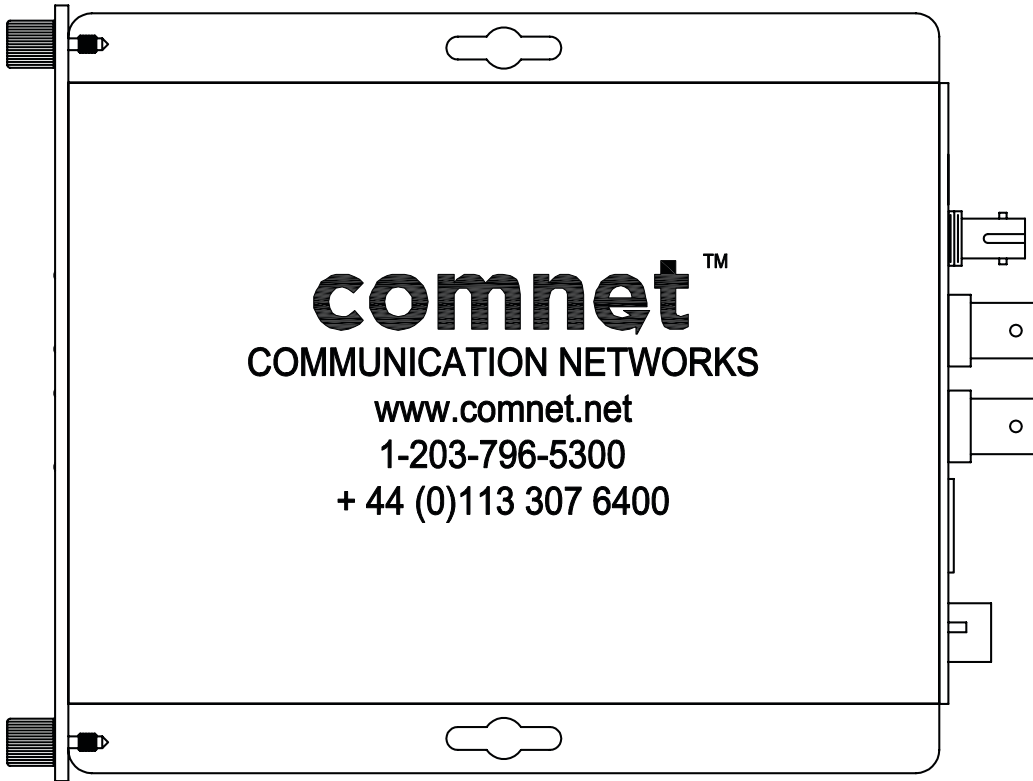

FRONT PANEL

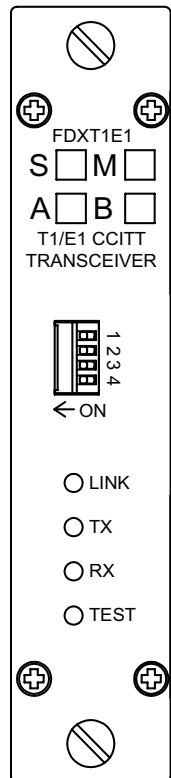

Data Format and Test Switches
 See Figure 7

LED Indicators
 See Figure 8

REAR PANEL

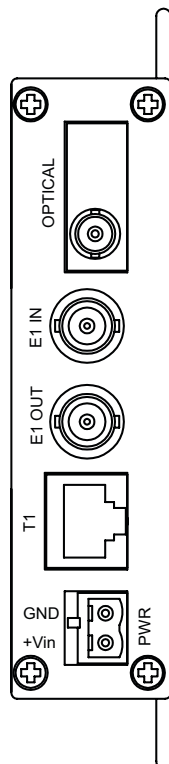

↔ Multimode Or Single Mode Optical Fiber
 (Depending On Model)

E1 Connections

T1 Connections

— BLACK
 - - - BLACK WITH WHITE STRIPE

Power Supply:
 Surface Mount: 24 VAC @ 1.2W
 Rack Mount: From ComNet Rack

FIGURE 2 - FDXT1/E1/R3 IFS-Compatible "R3" Units

SIDE VIEW

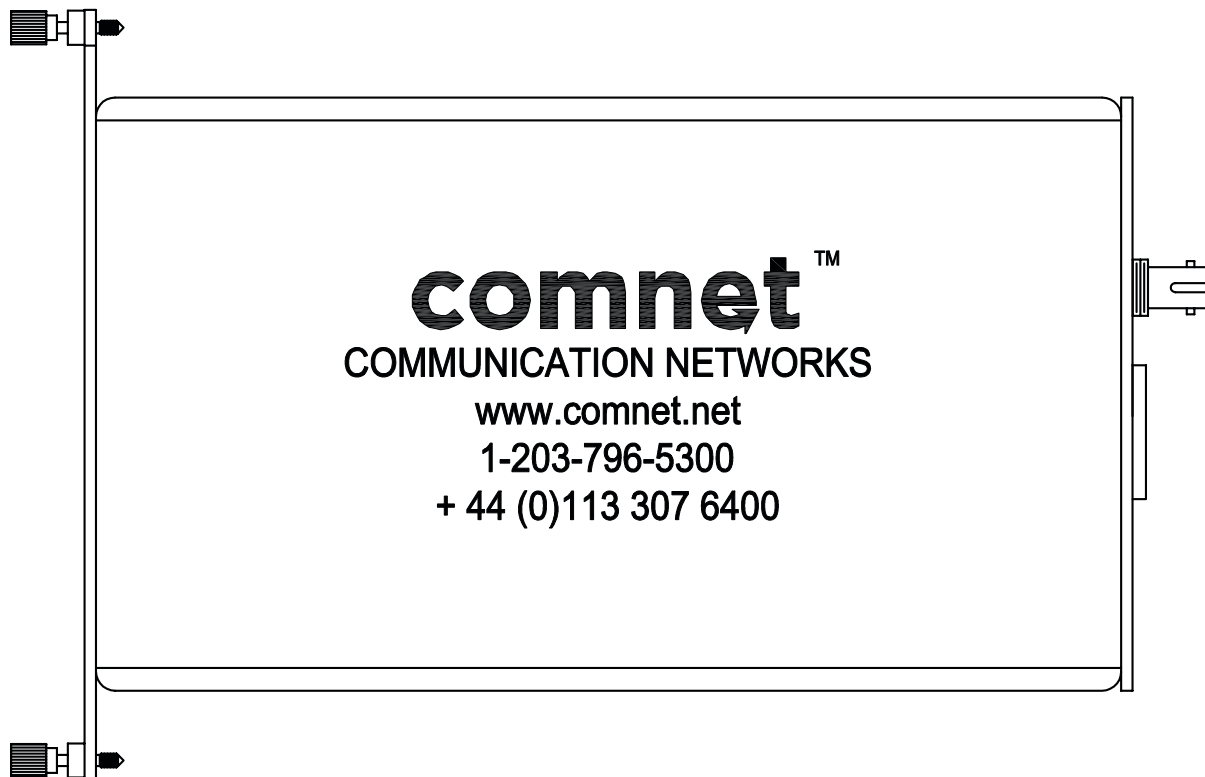

FRONT PANEL

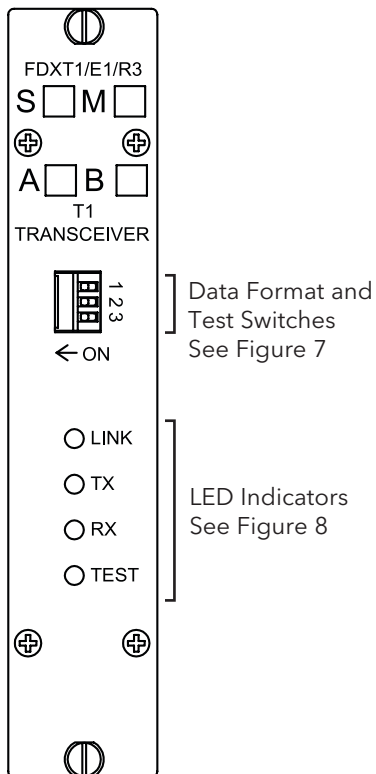

REAR PANEL

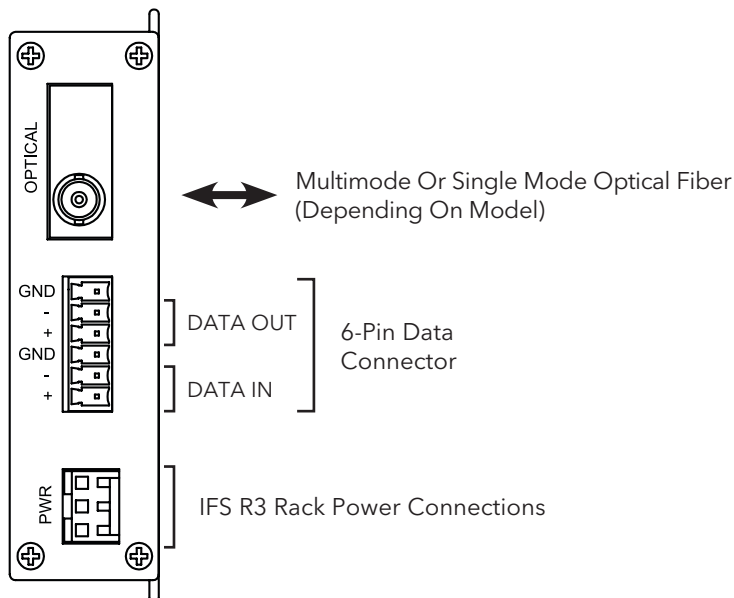
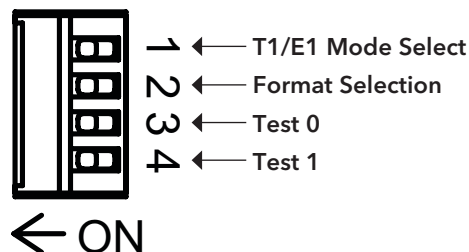

FIGURE 3 - FDXT1/E1 ComFit Unit Data Format Switch Positions

Switches are located on front panel.

T1/E1 Mode (Switch 1)	Description
On	T1 Mode
Off	E1 Mode

Format (Switch 2)	Description
On	AMI Data Format
Off	B8Zs Data Format



Test 0 (Switch 3)	Test 1 (Switch 4)	Test Label	Description
On	On	None	N/A
Off	On	Optical Loopback (Analog)	RX Fiber Input to TX Fiber Output Looped Back Internally through Analog Components
On	Off	Optical Loopback (Digital)	RX Fiber Input to TX Fiber Output Looped Back Internally through Digital Components
Off	Off	Local Loopback (Analog)	Loops Copper Received Data (P1, Pins 1 and 2) to Copper Transmit (P1, Pins 4 and 5)

FIGURE 4 - FDXT1/E1/R3 IFS-Compatible "R3" Unit Data Format Switch Positions

Switches are located on front panel.

Format (Switch 1)	Description
On	AMI Data Format
Off	B8Zs Data Format

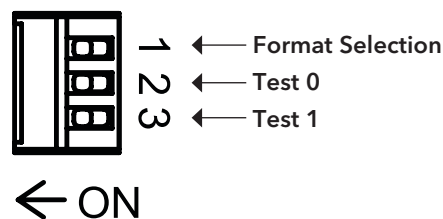

Test 0 (Switch 2)	Test 1 (Switch 3)	Test Label	Description
On	On	None	N/A
Off	On	Optical Loopback (Analog)	RX Fiber Input to TX Fiber Output Looped Back Internally through Analog Components
On	Off	Optical Loopback (Digital)	RX Fiber Input to TX Fiber Output Looped Back Internally through Digital Components
Off	Off	Local Loopback (Analog)	Loops Copper Received Data (P1, Pins 1 and 2) to Copper Transmit (P1, Pins 4 and 5)

FIGURE 5 - T1/E1 DATA CONNECTIONS

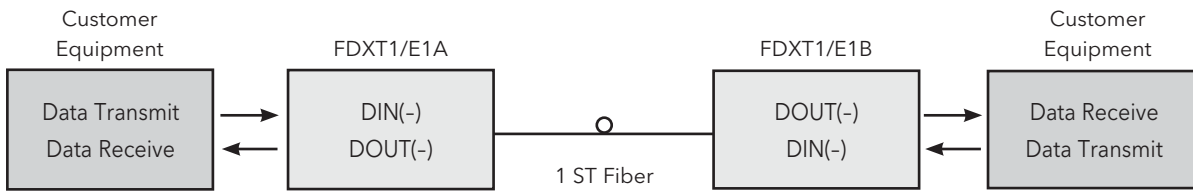

FIGURE 6 - LED INDICATORS

	LINK	TX	RX	TEST
GREEN	Unit In Sync	Data Activity	Data Activity	Test Mode Off (Normal Operation)
RED	Unit Not In Sync	-	-	Test Mode On
OFF	-	No Data Activity	No Data Activity	-

MECHANICAL INSTALLATION INSTRUCTIONS

INSTALLATION CONSIDERATIONS

The ComFit unit fiber-optic link is supplied as a Standalone/Rack module. Units should be installed in dry locations protected from extremes of temperature and humidity.

The R3 IFS-Compatible unit fiber-optic link is supplied as a Rack module only, and should only be used in the IFS R3 rack. Units should be installed in dry locations protected from extremes of temperature and humidity.

C1-US, C1-EU, C1-AU OR C1-CH CARD CAGE RACKS

CAUTION: Although the units are hot-swappable and may be installed without turning power off to the rack, ComNet recommends that the power supply be turned off and that the rack power supply is disconnected from any power source. **Note:** Remove electrical connector before installing in card cage rack.

1. Make sure that the card is oriented right side up, and slide it into the card guides in the rack until the edge connector at the back of the card seats in the corresponding slot in the rack's connector panel. Seating may require thumb pressure on the top and bottom of the card's front panel.

CAUTION: Take care not to press on any of the LEDs.

2. Tighten the two thumb screws on the card until the front panel of the card is seated against the front of the rack.

WARNING: Unit is to be used with a Listed Class 2 power supply.

IMPORTANT SAFEGUARDS:

- A) **Elevated Operating Ambient** - If installed in a closed or multi-unit rack assembly, the operating ambient temperature of the rack environment may be greater than room ambient. Therefore, consideration should be given to installing the equipment in an environment compatible with the maximum ambient temperature (T_{ma}) specified by the manufacturer.
- B) **Reduced Air Flow** - Installation of the equipment in a rack should be such that the amount of air flow required for safe operation of the equipment is not compromised.



3 CORPORATE DRIVE | DANBURY, CT 06810 | USA
T: 203.796.5300 | F: 203.796.5303 | TECH SUPPORT: 1.888.678.9427 | INFO@COMNET.NET
8 TURNBERRY PARK ROAD | GILDERSOME | MORLEY | LEEDS, UK LS27 7LE
T: +44 (0)113 307 6400 | F: +44 (0)113 253 7462 | INFO-EUROPE@COMNET.NET

FIGURE A

Dimensions are for a standard ComNet™ one slot module

