



INSTALLATION AND OPERATION MANUAL

FDC8ISOT(M,S)1

8-CHANNEL OPTICALLY ISOLATED CONTACT CLOSURE TRANSMITTER

The FDC8ISOT 8-Channel Contact Closure Transmitter unit provides up to eight independent normally-open (NO) dry contact closures over one multimode or single-mode optical fiber, when used in conjunction with the companion ComNet model FDC8NLR Non-Latching Receiver or FDC8R Latching Receiver units. Each of the contact closure inputs are optically isolated at 1500V to ground, for those applications where high stray or transient voltages may exist. Microprocessor-based logic in the FDC8ISOT Transmitter detects a customer-furnished switch or contact closure, and encodes the closure into robust data packets that are mapped and transmitted to the FDC8NLR Receiver. Packets received with excessive bit errors will not result in random changes in the receiver relay contact resting or actuated states, making this system ideal for mission-critical remote switching applications. See **Figure 3** on **Page 3** for contact settings.

These transmitter modules incorporate status indicating LEDs for rapidly providing a local indication of each contact closure channel and operating power. See **Figure 4** on **Page 3** for an explanation of the LED indicators.

Packaged in the exclusive ComNet ComFit housing, these units may be either shelf or rack-mounted, or may be DIN-rail mounted by the addition of ComNet model DINBKT1 Adaptor Plate Kit. See **Figure A** on **Page 4** for mounting instructions.

See **Figures 1 – 4** for complete installation information.

FIGURE 1 – FDC8ISOT TRANSMITTER

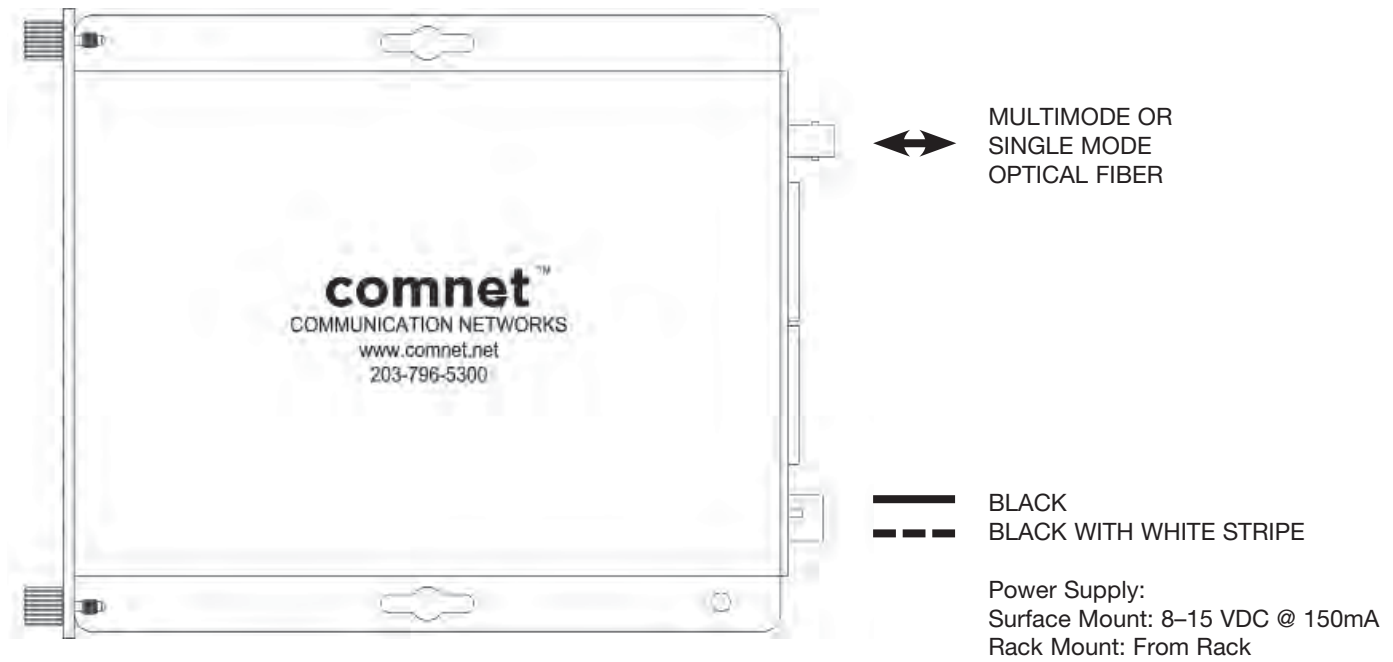

FIGURE 2 – FDC8ISOT TRANSMITTER

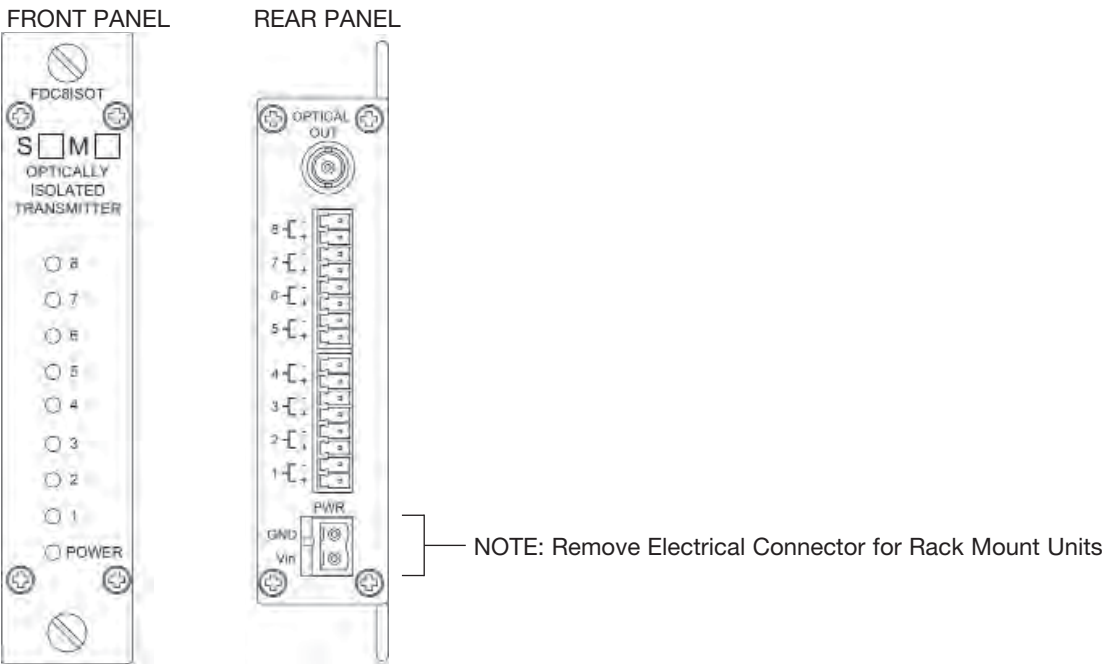

FIGURE 3 – TYPICAL RELAY SETTINGS

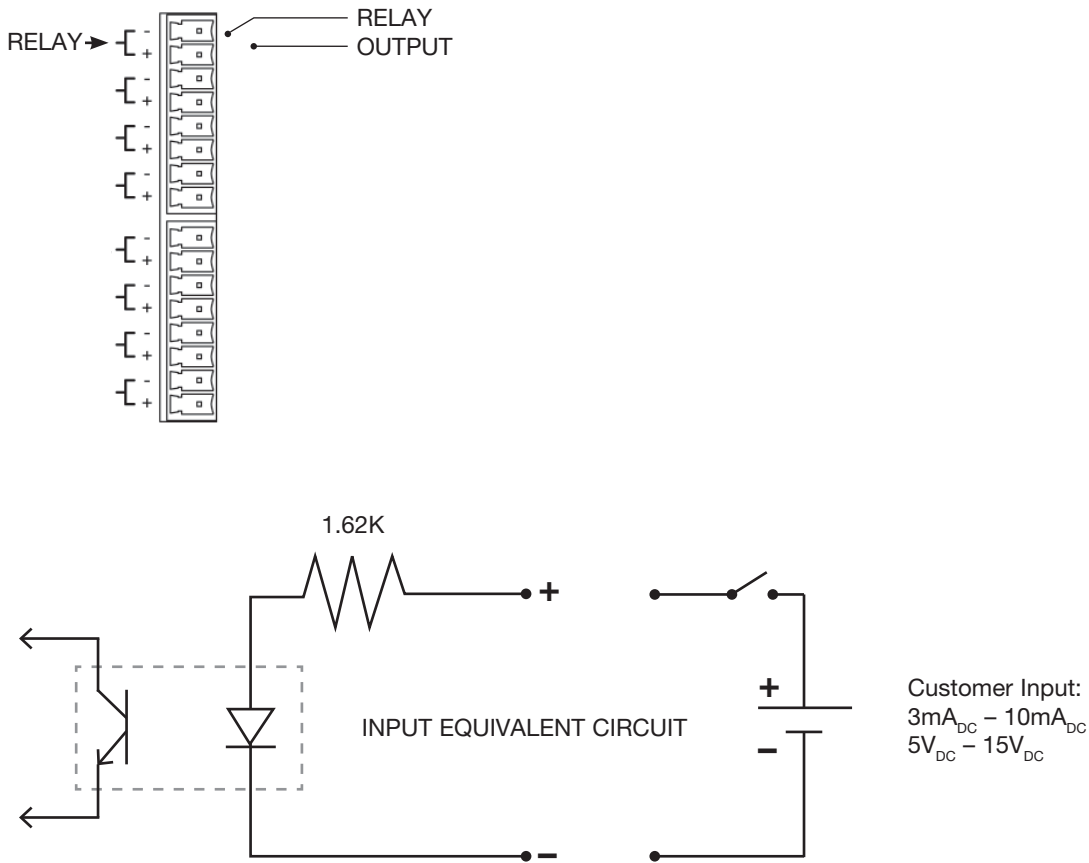

FIGURE 4 – LED INDICATORS

	CONTACT (1 – 8)	POWER
GREEN	An active signal is present.	Unit powered up
RED	No activity	–
OFF	Unit powered down	

MECHANICAL INSTALLATION INSTRUCTIONS

INSTALLATION CONSIDERATIONS

This fiber-optic link is supplied as a Standalone/Rack module. Units should be installed in dry locations protected from extremes of temperature and humidity.

C1-US, C1-EU, C1-AU OR C1-CH CARD CAGE RACKS

CAUTION: Although the units are hot-swappable and may be installed without turning power off to the rack, ComNet recommends that the power supply be turned off and that the rack power supply is disconnected from any power source. **Note:** Remove electrical connector before installing in card cage rack.

1. Make sure that the card is oriented right side up, and slide it into the card guides in the rack until the edge connector at the back of the card seats in the corresponding slot in the rack's connector panel. Seating may require thumb pressure on the top and bottom of the card's front panel.

CAUTION: Take care not to press on any of the LEDs.

2. Tighten the two thumb screws on the card until the front panel of the card is seated against the front of the rack.

WARNING: Unit is to be used with a Listed Class 2 or LPS power supply rated 9-12 VDC @ 1A.

IMPORTANT SAFEGUARDS:

A) Elevated Operating Ambient - If installed in a closed or multi-unit rack assembly, the operating ambient temperature of the rack environment may be greater than room ambient. Therefore, consideration should be given to installing the equipment in an environment compatible with the maximum ambient temperature (T_{ma}) specified by the manufacturer.

B) Reduced Air Flow - Installation of the equipment in a rack should be such that the amount of air flow required for safe operation of the equipment is not compromised.

FIGURE A

Dimensions are for a standard ComNet one slot module

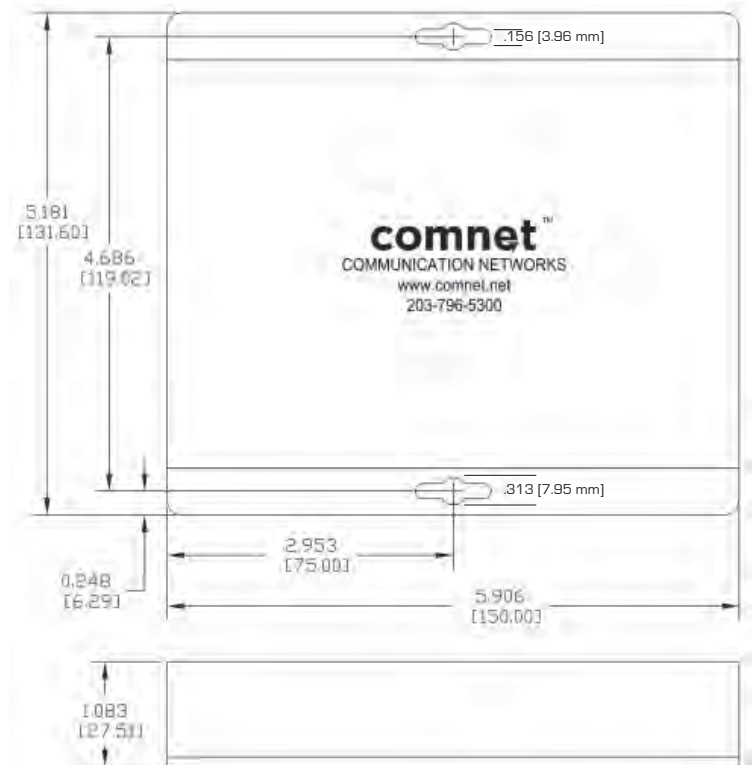

MADE IN THE
USA

comnet
Communication Networks

3 CORPORATE DRIVE | DANBURY, CT 06810 | USA
T: 203.796.5300 | F: 203.796.5303 | TECH SUPPORT: 1.888.678.9427 | INFO@COMNET.NET

8 TURNBERRY PARK ROAD | GILDERSOME | MORLEY | LEEDS, UK LS27 7LE
T: +44 (0)113 307 6400 | F: +44 (0)113 253 7462 | INFO-EUROPE@COMNET.NET